

**CMC**  
THE SPECIALIFT

**F SERIES**  
FULL HYDRAULIC





# F SERIES

FULL HYDRAULIC

**Fully hydraulic, simply perfect, ideal for rental.**

The letter F identifies the CMC's family of fully hydraulic platforms, with working heights from 13m to 18m, featuring a simple and intuitive control system which allows the machine to be used almost immediately by novice users.

If we add to this the extreme versatility for outdoor and indoor use, the longest outreach compared to the other machines in the same category, the ease of transport with a trailer or small van, the automatic outriggers stabilisation with radio remote control (options) and the extreme simplicity of maintenance, then it's easy to understand why the CMC F series platforms are the perfect choice for any rental company's fleet.

**S13F**



**S15F**



**S18F**



# BENEFITS



## Easy to transport

The hydraulic proportional control system is intuitive and easy to use, with their low weight, the CMC F-series platforms can be loaded on trailers and be transported easily anywhere.

## Versatile to use

The full hydraulic system of the CMC F series platforms not only makes them easy to use, but it's also simple to maintain, making them particularly resistant to wear and tear of time.

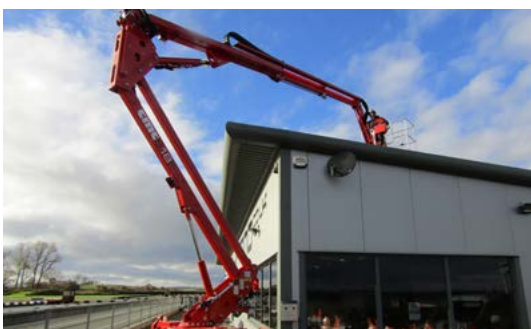

## Simply to use

The hydraulic proportional control system is intuitive and easy to use, allowing the CMC F Series platforms to be used correctly by all types of users.

Manoeuvrability is also enhanced by the possibility of operating the telescopic boom with the jib in rest position.

# FEATURES

200 bar air/water hose and 230V and 12V socket in the basket

Radio remote control for track drive and automatic leveling of outriggers



Two-man basket with quick release system and wheels

Self-diagnosis display

Several engines available

Hydraulic proportional controls

Protective cover on the cylinder of the outriggers

Hydraulically adjustable undercarriage in height and width\*

Some available options	S13F	S15F	S18F
Yanmar diesel engine	●	●	●
Version with full lithium battery (160 Ah)	●	●	●
Grey non-marking tracks	●	●	●
Basket rotation (+/-90 )	●	●	●
Fiberglass basket 1 or 2 man	●	●	●
Remote connection with Sim Card and GPS Locator	●	●	●
Custom colours	●	●	●
Remote control for tracks control and automatic self-levelling outriggers	●	●	●

\*available only on S15F and S18F

# CMC PLATFORMS APPLICATIONS



## **Refurbishment building works**

even in places with difficult access such as worship places, historical buildings, hotels, and shopping centres.

**Facilities management**  
in mainly restricted traffic areas or in locations that are difficult for truck-mounted platforms.



## **Pruning tall trees**

and even operating in tight spaces inside private homes on particularly delicate turf.



# TECHNICAL DATA

# S13F

## PERFORMANCE AND DIMENSIONS



### Main features

Lightweight and multifunctional, equipped with a two-stage telescopic boom and jib (90°), the S13F is the smallest platform in the entire CMC range and the most compact in its category, but it is second to none when it comes to work in difficult conditions and limited spaces.

Max. working height	<b>12,9 m</b>
Max. outreach	<b>8,5 m</b>
Platform height	<b>10,9 m</b>
Max. load in basket	<b>230 kg</b>
Basket dimensions	<b>1,4 x 0,7 x 1,1 m</b>
Basket rotation	<b>+/- 90° (options)</b>
Turret rotation	<b>+/- 178° (356° non-continuous)</b>
Total weight	<b>1565 Kg</b>

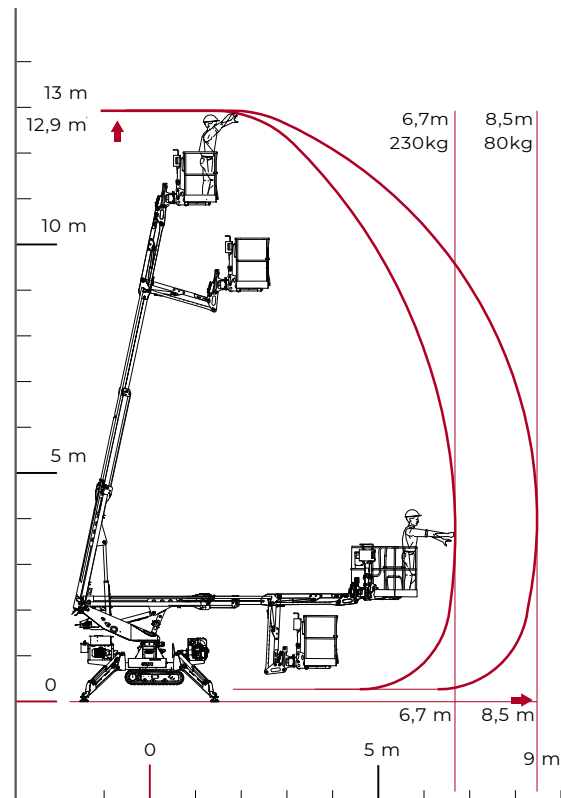

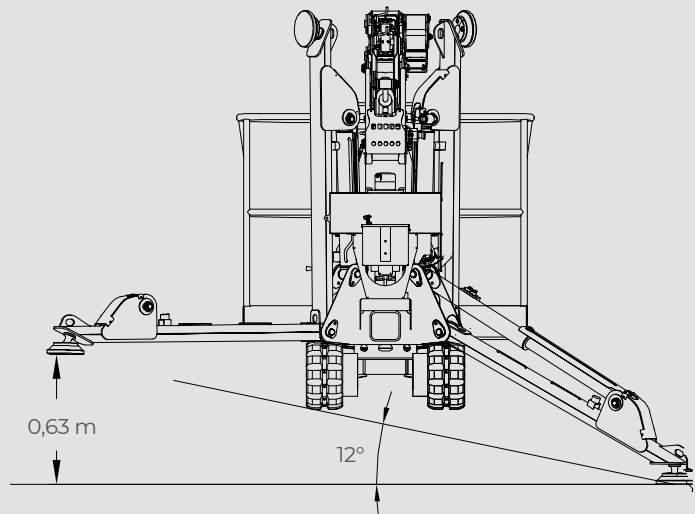
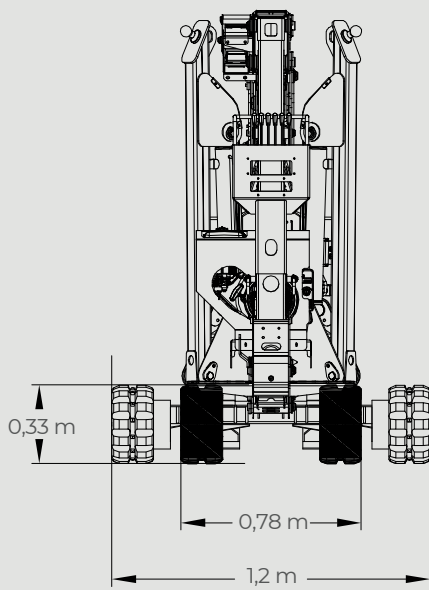
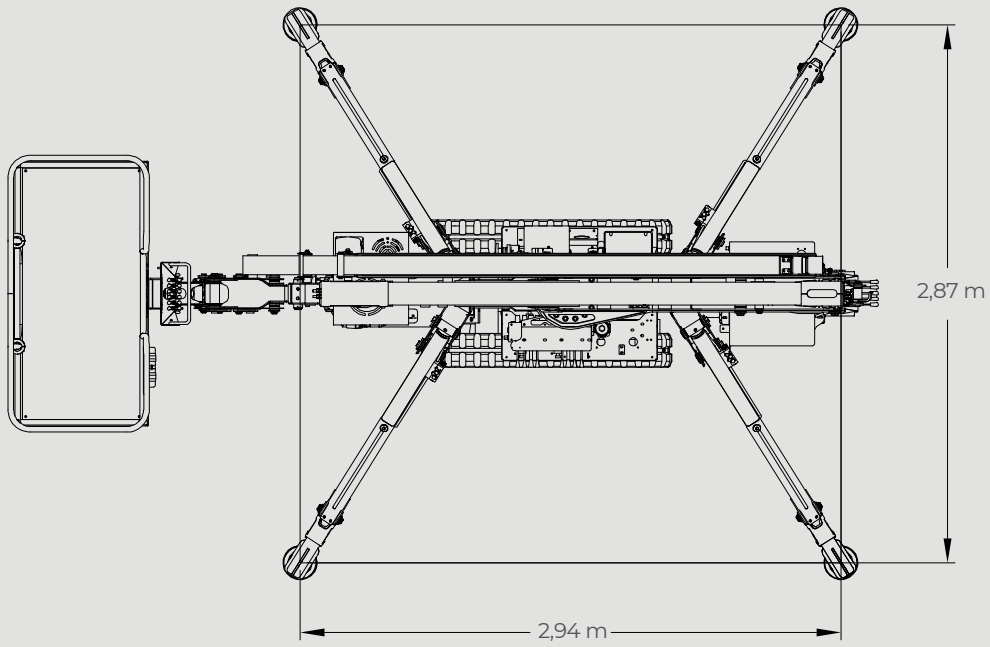
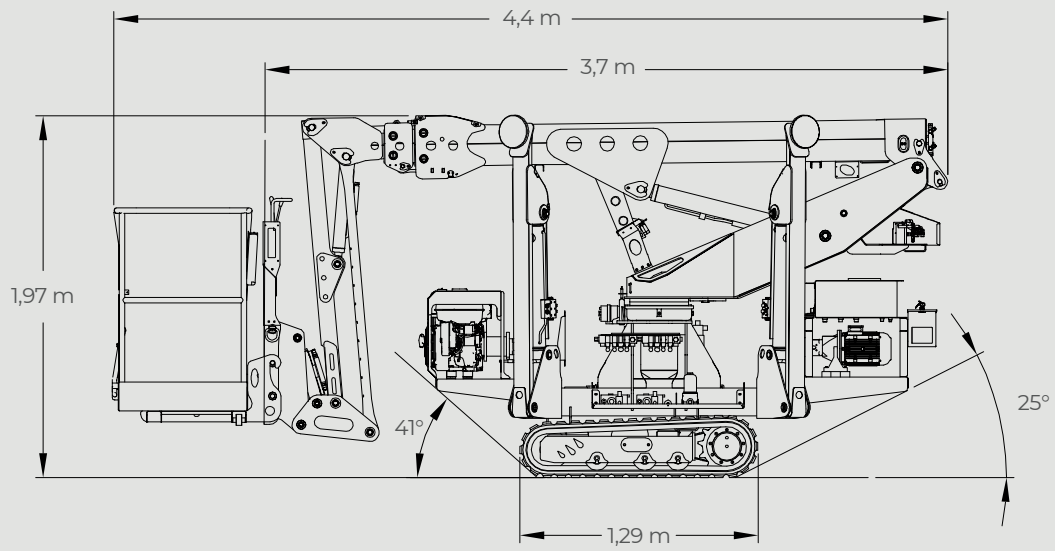

\*data may can change due to updates of components

# TECHNICAL DATA

# S15F

## PERFORMANCE AND DIMENSIONS



### Main features

Geometric platform without outreach limiting device, with pantograph and single telescopic boom plus jib. It offers excellent performance in all types of work, thanks to a compact stabilisation area that provides maximum stability even on the most difficult terrains.

Max. working height	<b>14,8 m</b>
Max. outreach	<b>8,7 m</b>
Platform height	<b>12,8 m</b>
Max. load in basket	<b>200 kg</b>
Basket dimensions	<b>1,4 x 0,7 x 1,1 m</b>
Basket dimensions	<b>+/-90° (options)</b>
Turret rotation	<b>+/- 178° (356° non-continuous)</b>
Total weight	<b>2378 Kg</b>

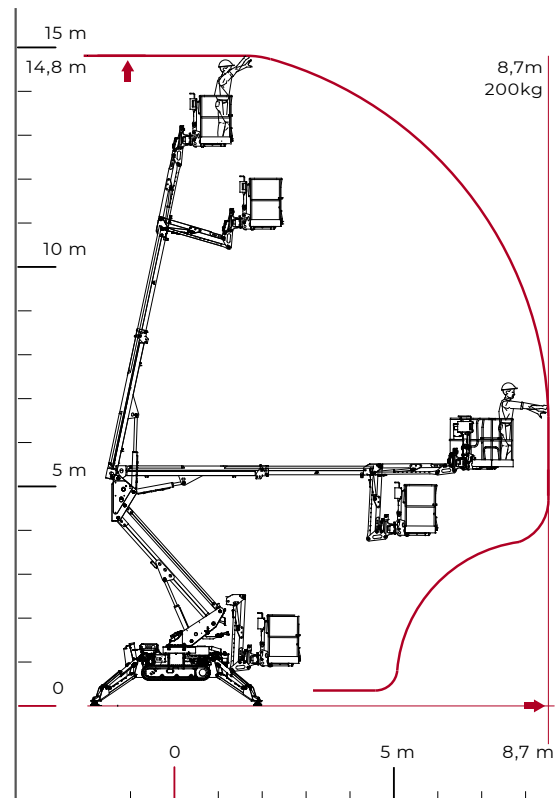

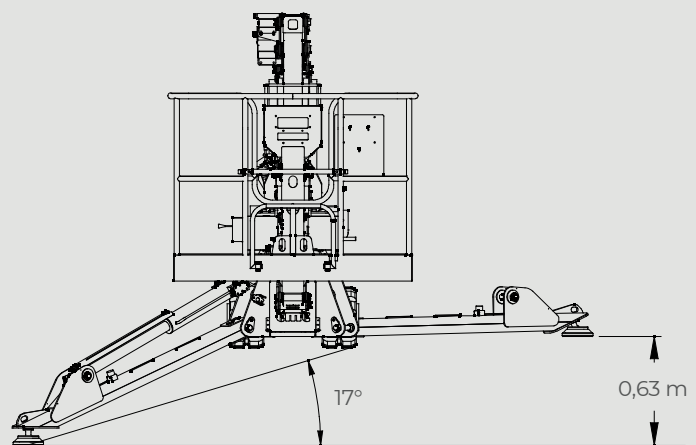
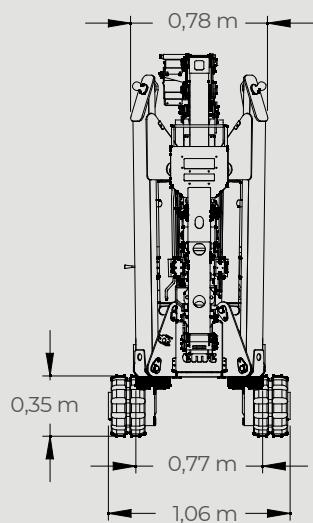
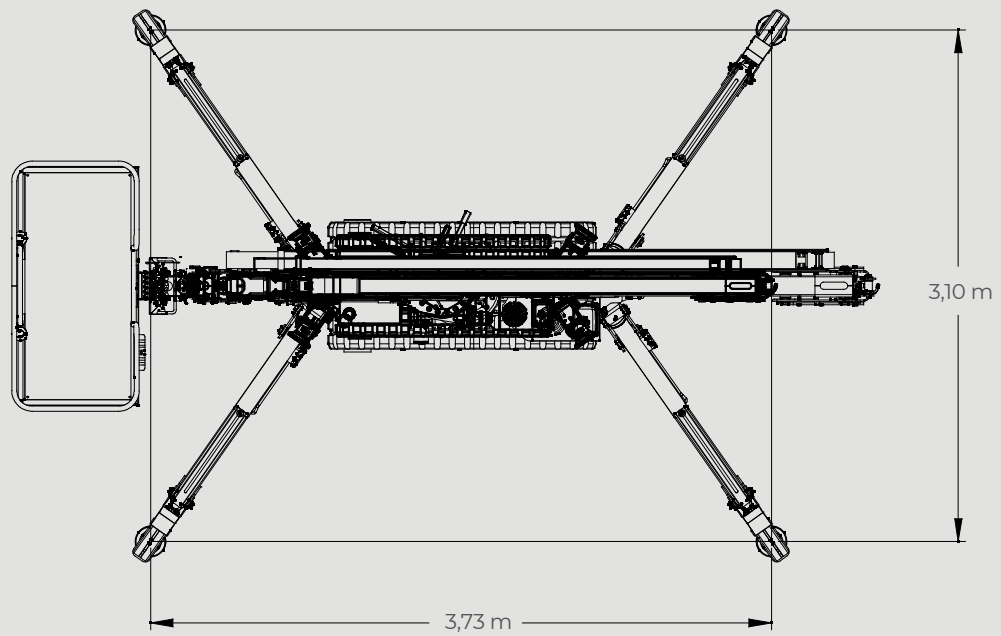
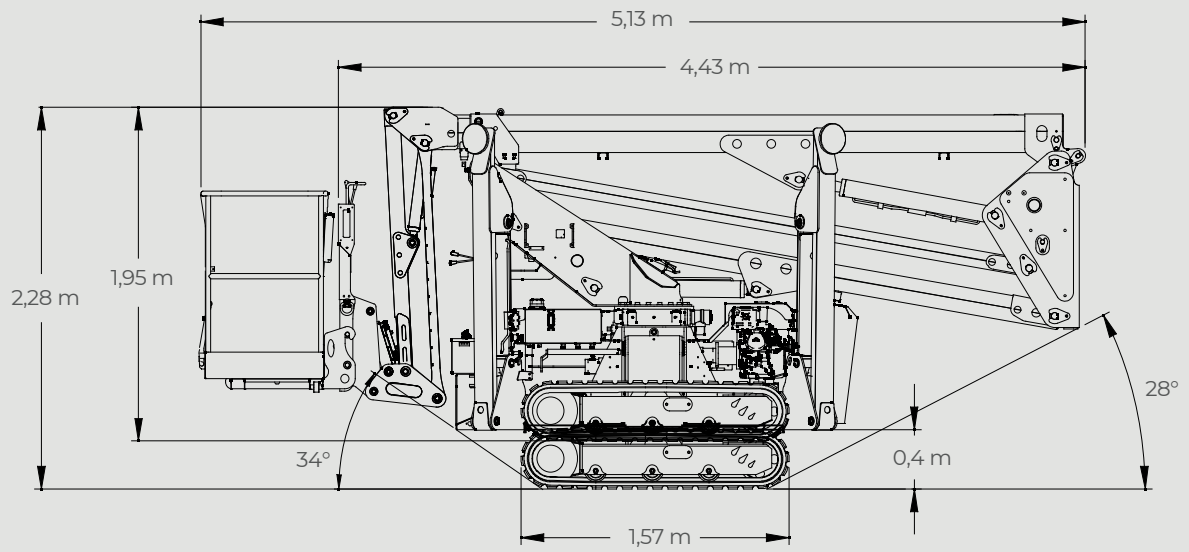

\*data may can change due to updates of components

# TECHNICAL DATA

# S18F

## PERFORMANCE AND DIMENSIONS



### Main features

Equipped with a single pantograph and a two-stage telescopic boom plus jib, mechanically adjustable tracks in height and width and with an impressive lateral outreach, this is a multipurpose aerial platform with amazing performance which fully meets the needs of the both end user and rental company.

Max. working height	<b>17,78 m</b>
Max. outreach	<b>11,15 m</b>
Platform height	<b>15,78 m</b>
Max. load in basket	<b>230 kg</b>
Basket dimensions	<b>1,4 x 0,7 x 1,1 m</b>
Basket rotation	<b>+/-90° (options)</b>
Turret rotation	<b>+/- 178° (356° non-continuous)</b>
Total weight	<b>2495 Kg</b>

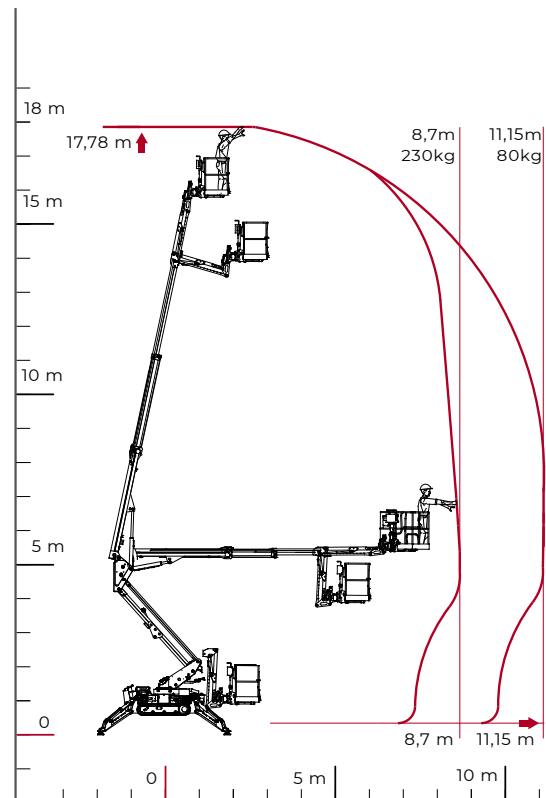

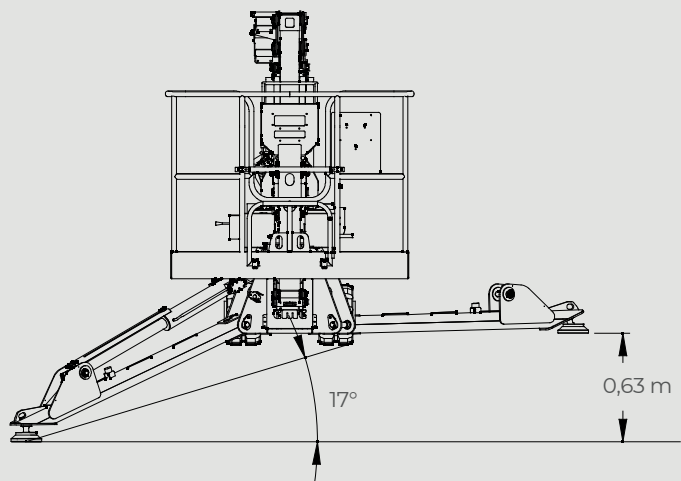
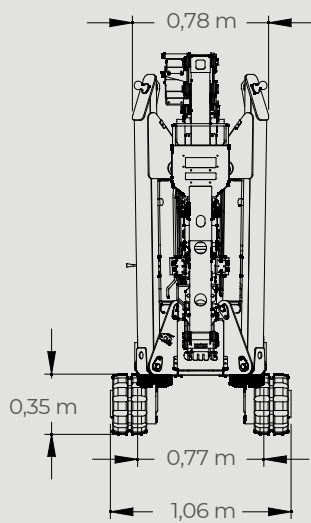
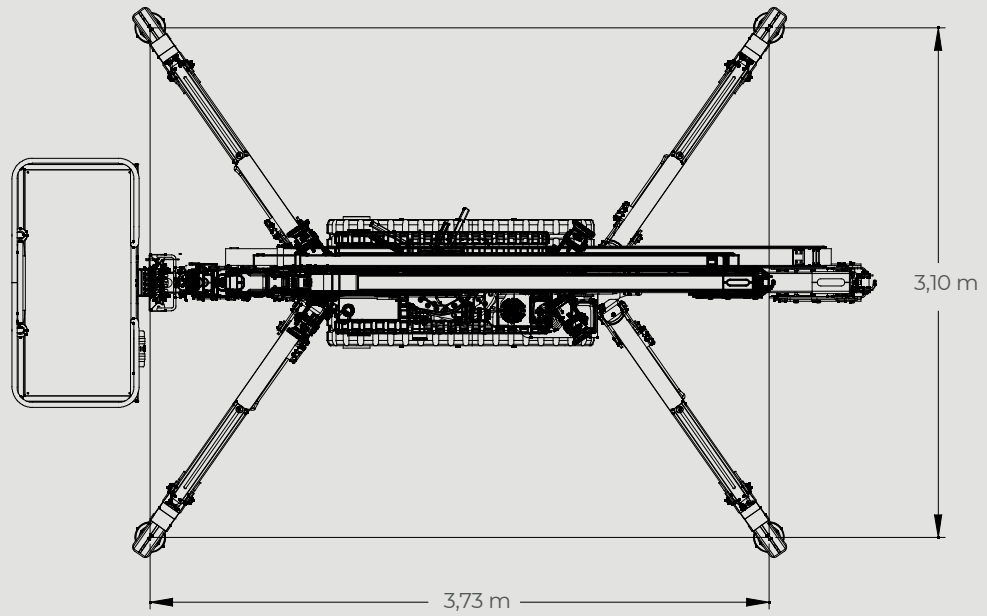
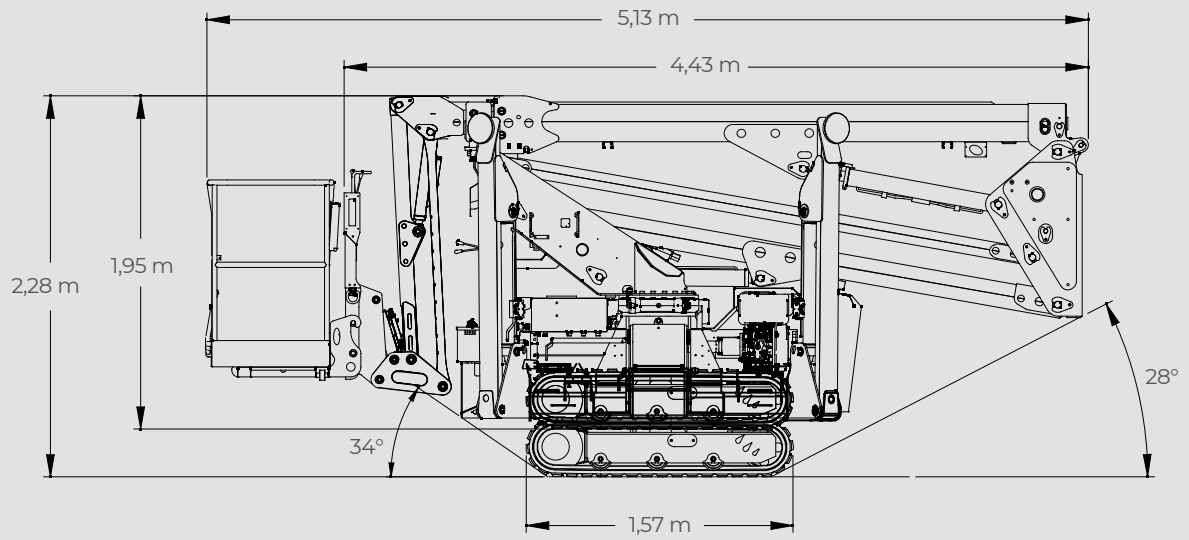

\*data may can change due to updates of components





## CMC SELF-PROPELLED CRAWLER PLATFORMS

### F SERIES

MODEL	MAX. WORKING HEIGHT	MAX. OUTREACH	WEIGHT
S13F	12,9 m	8,5 m	1565 Kg
S15F	14,8 m	8,7 m	2378 Kg
S18F	17,78 m	11,15 m	2495 Kg

### LC SERIES

MODEL	MAX. WORKING HEIGHT	MAX. OUTREACH	WEIGHT
S15	14,9 m	6,9 m	1820 Kg
S19E	18,7 m	9,3 m	2545 Kg
S19N	18,9 m	9,5 m	2435 Kg
S23	23 m	12,4 m	2880 Kg

### HD SERIES

MODEL	MAX. WORKING HEIGHT	MAX. OUTREACH	WEIGHT
S19HD	18,7 m	11,4 m	2685 Kg
S22HD	21,6 m	12,5 m	3025 Kg

### DP SERIES

MODEL	MAX. WORKING HEIGHT	MAX. OUTREACH	WEIGHT
S27	27,3 m	15,4 m	4109 Kg
S30	30,3 m	15,4 m	4285 Kg
S32	32 m	16 m	7255 Kg

### XL SERIES

MODEL	MAX. WORKING HEIGHT	MAX. OUTREACH	WEIGHT
S41	41 m	19 m	13460 Kg

### i SERIES

MODEL	MAX. WORKING HEIGHT	MAX. OUTREACH	WEIGHT
i23	23 m	10 m	3930 Kg

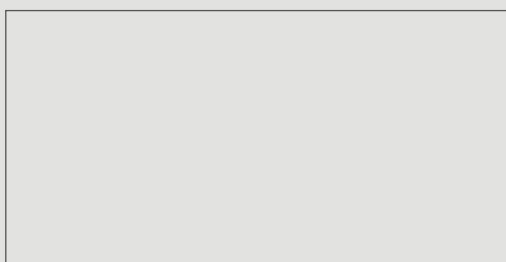

**CMC**  
THE SPECIALIFT

Via Bitritto, 119 - 70124 BARI - ITALY  
Tel. +39 080 532 66 06 - Fax +39 080 536 85 41  
www.cmclift.com - info@cmclift.com

Follow us on

