

CMC
THE SPECIALIFT

LC SERIES
LIGHT AND COMPACT





LC SERIES

LIGHT AND COMPACT

Double pantograph, low weight, ideal for indoor use.

Reduced weight and maximum compactness: these are some of the qualities which identify the widest family of CMC platforms. Four different models with double pantograph and telescopic boom plus jib, designed and built to give the best operating efficiency, versatility of use and transportability.

They range from the small S15, ideal for working inside large buildings, to the medium-sized S19E, without outreach limits in terms of the load in the basket, moving to the S19N, which, thanks to the narrowest stabilisation area in its category, can work in very small spaces, finishing with the “multipurpose” S23, the latest designed platform featuring great performance which expresses the best of all CMC’s experience and technological capabilities.

S15



S19E



S19N



S23



BENEFITS



Ease of transport

Thanks to their low weight (under 3000 kg), the CMC LC series platforms can be loaded and transported on a trailer.

Versatility of use

The four articulated platform of the LC series with double pantograph and telescopic boom plus jib and three stabilisation areas, are able to reach anywhere and operate in all conditions.



Ease of use

Several operations can be carried out at the same time via radio control or wired control, in a simple and intuitive way, with smooth and accurate movement.

FEATURES

200 bar air/water hose and 230 V and 12 V socket in basket

Radio remote control

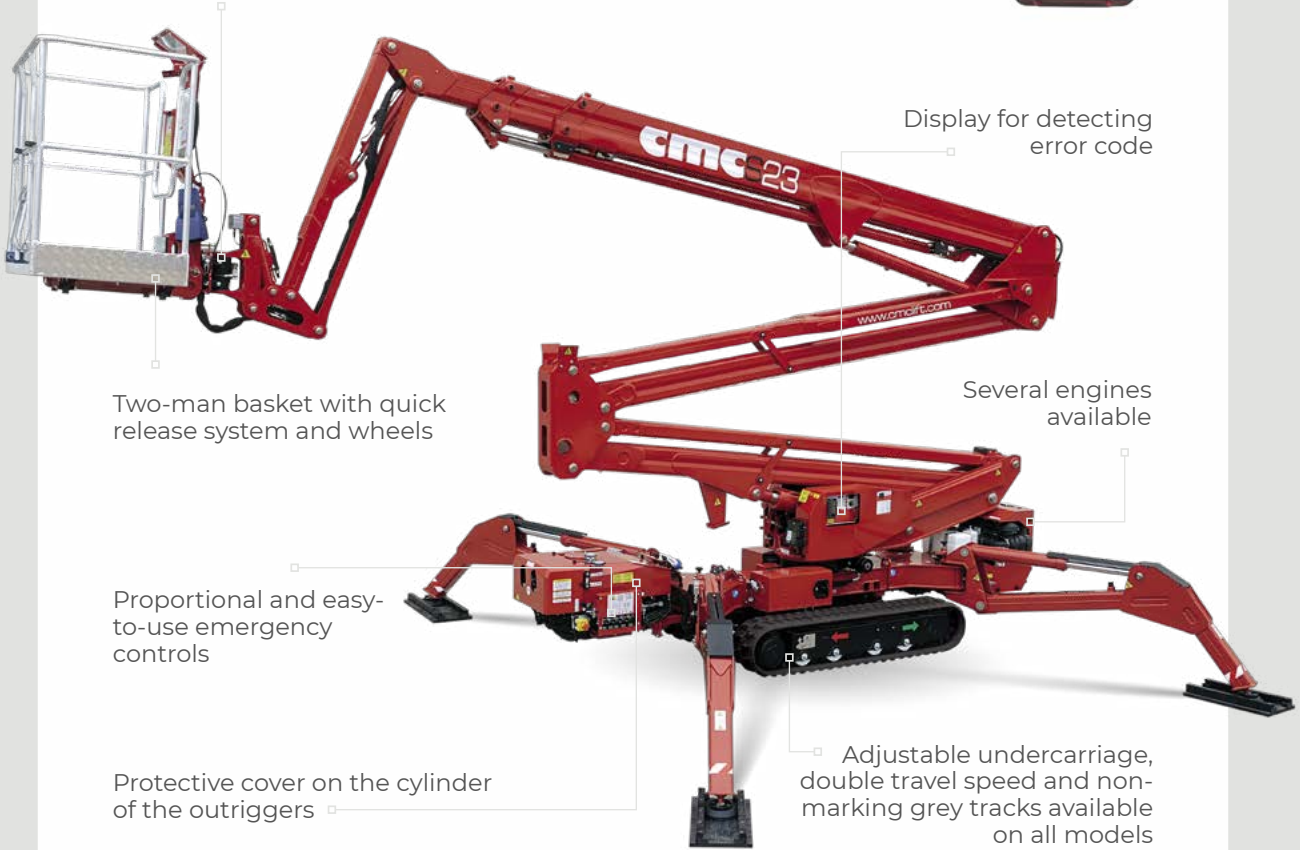

Display for detecting error code

Two-man basket with quick release system and wheels

Several engines available

Proportional and easy-to-use emergency controls

Protective cover on the cylinder of the outriggers

Adjustable undercarriage, double travel speed and non-marking grey tracks available on all models

Some available options	S15	S19E	S19N	S23
Kubota Z482 diesel engine	●	●	●	
Kubota Z602 diesel engine				●
Yanmar L100V engine	●	●	●	
Full lithium version	●	●	●	●
Electric motor 230V, 120V, 110V	●	●	●	●
Grey non-marking tracks	●	●	●	●
Hydraulically adjustable undercarriage	●	●	●	●
Double travel speed	●	●	●	●
Remote connection with Sim Card and GPS Locator	●	●	●	●
Custom colours	●	●	●	●
12V emergency electric pump	●	●	●	●

CMC PLATFORMS APPLICATIONS



Refurbishment building works
even in places with difficult access
such as worship places, historical
buildings, hotels, and shopping
centres.

Facilities management
in mainly restricted traffic areas or in
locations that are difficult for truck-
mounted platforms.



Pruning tall trees
and even operating in tight spaces
inside private homes on particularly
delicate turf.



TECHNICAL DATA

S15

PERFORMANCE AND DIMENSIONS



Main features

This is the most compact geometric platform without outreach limiter in its class. It goes through a standard door and fit in the lifts, a key feature for use inside large buildings such as such as airports or large shopping centres.

Max. working height	14,9 m
Max. outreach	6,9 m
Platform height	12,9 m
Max. load in basket	230 kg
Basket dimensions	1,4 x 0,7 x 1,1 m
Basket rotation	+/-90° (option)
Turret rotation	+/- 178° (356° non-continuous)
Total weight	1820 Kg

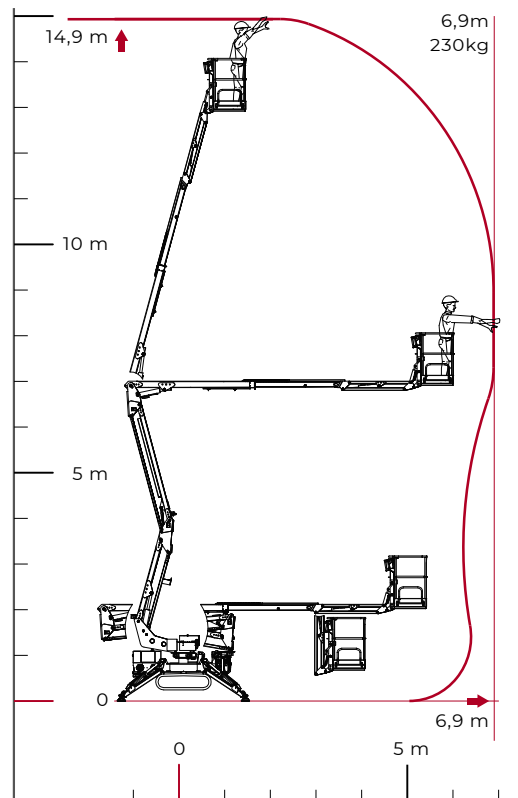

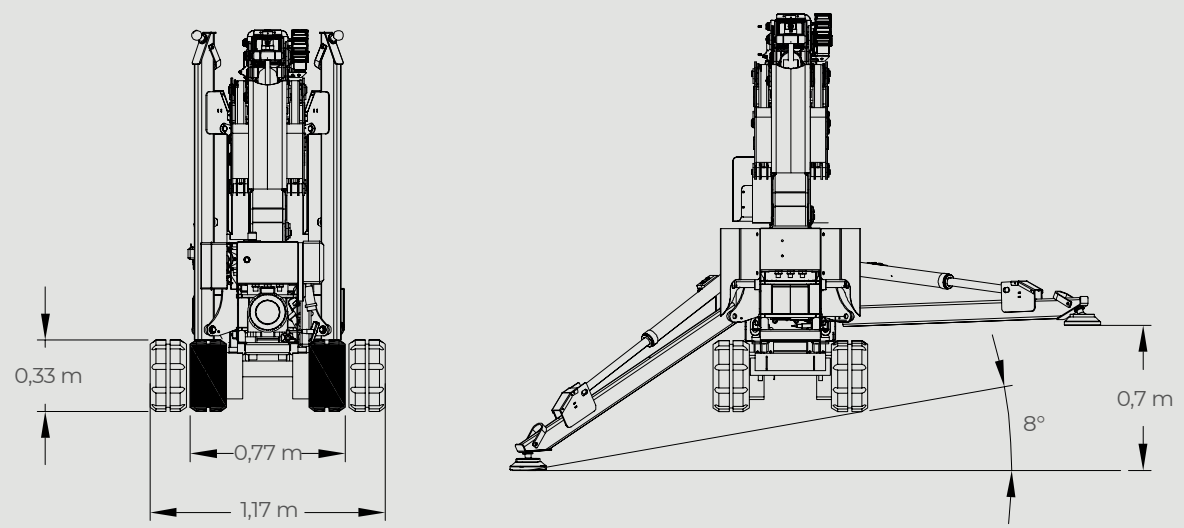
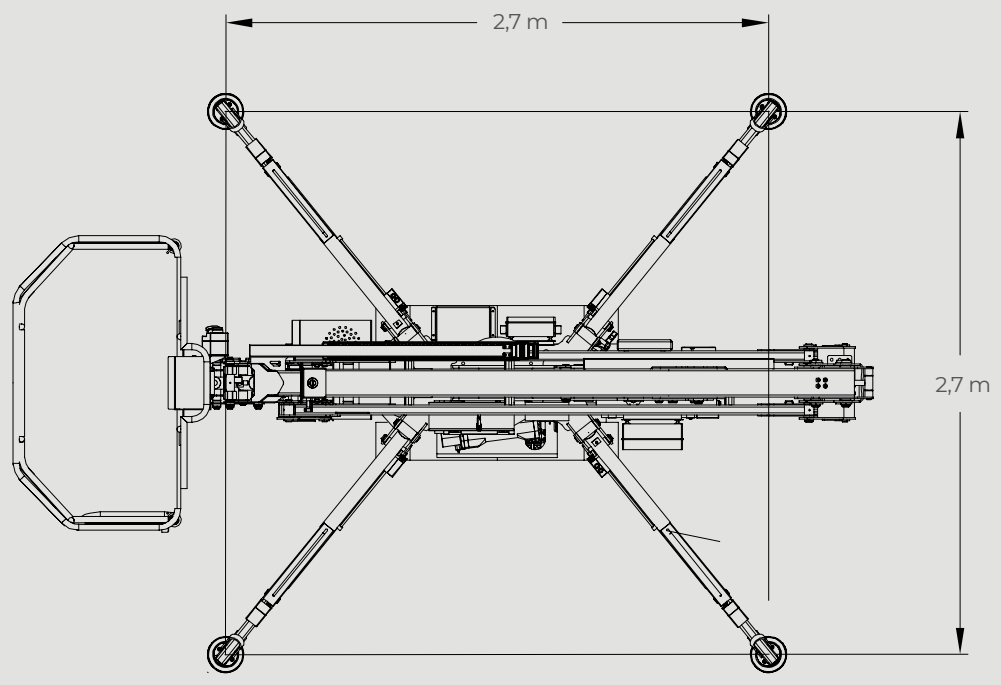
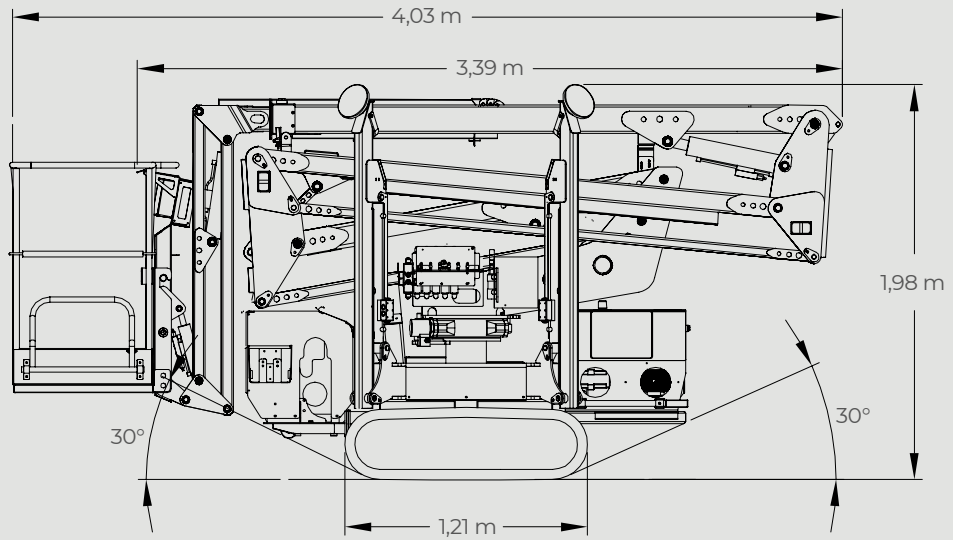

*data may can change due to updates of components

TECHNICAL DATA

S19E

PERFORMANCE AND DIMENSIONS



Main features

It is a geometric platform, without outreach limiter device, with low weight and extreme compactness, easy to transport on a trailer and suitable for any type of application.

Max. working height	18,7 m
Max. outreach	9,3 m
Platform height	16,7 m
Max. load in basket	200 kg
Basket dimensions	1,4 x 0,7 x 1,1 m
Turret rotation	+/- 178° (356° non-continuous)
Total weight	2545 Kg

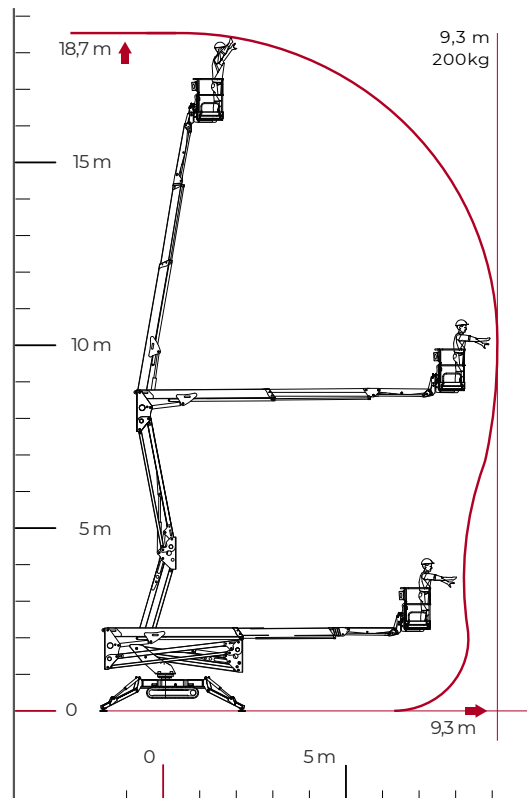

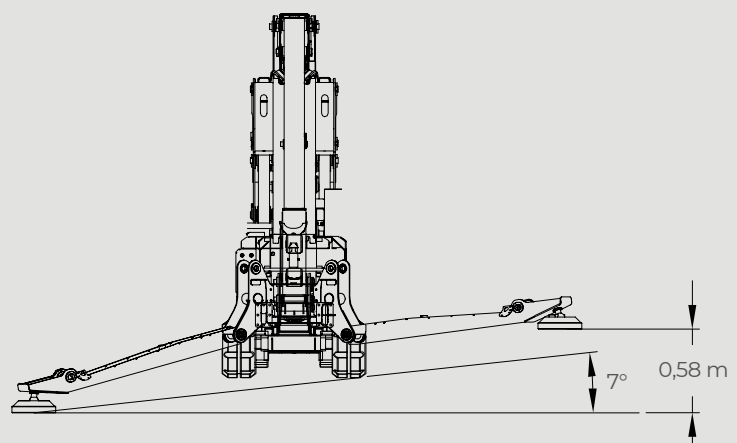
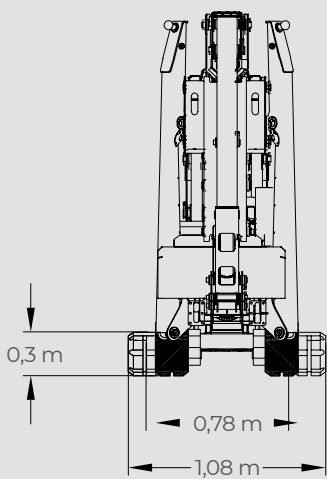
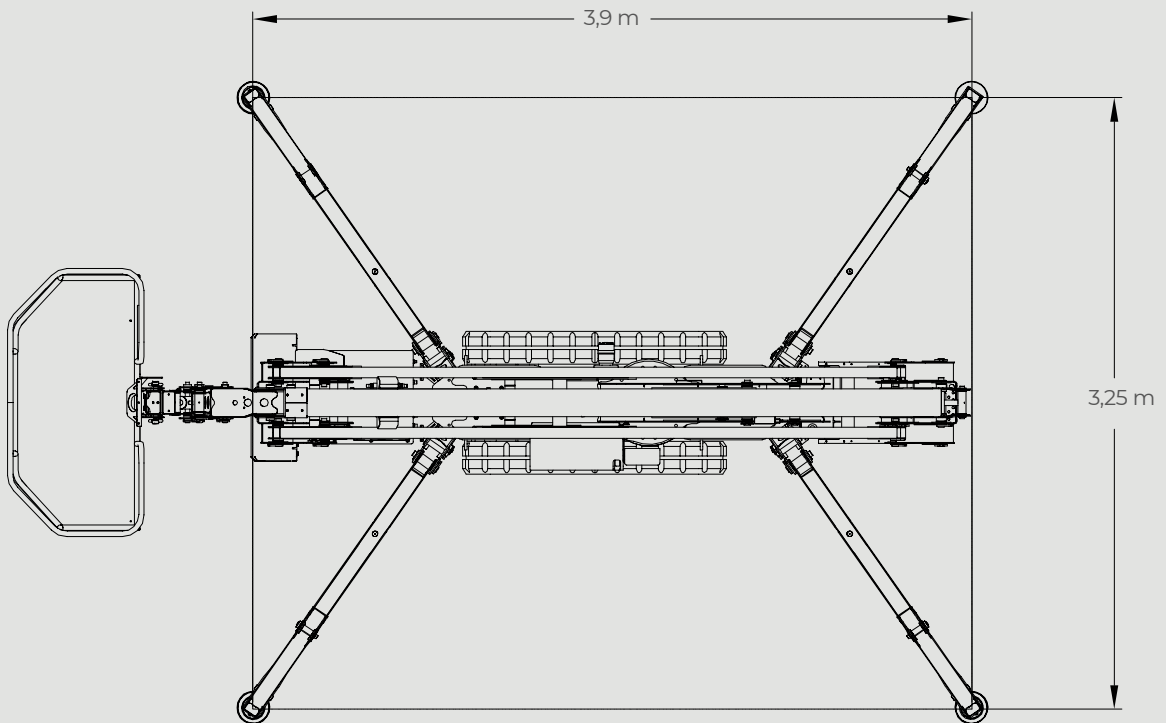
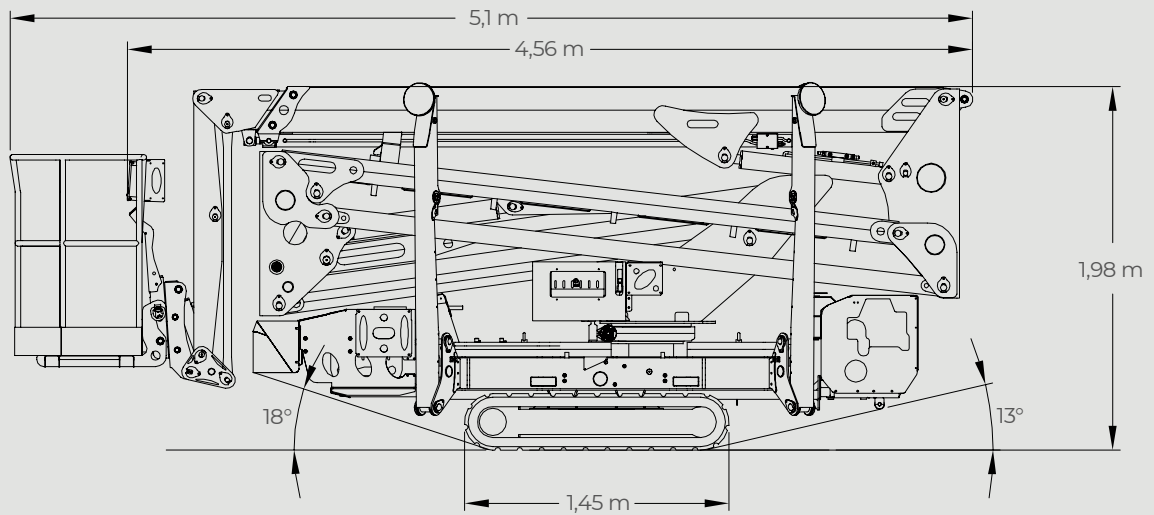

*data may can change due to updates of components

TECHNICAL DATA

S19N

PERFORMANCE AND DIMENSIONS



Main features

N for Narrow, this platform features the narrowest stabilisation area in its category. It's the best tool to work in tight spaces without compromising the outreach performance.

Max. working height	18,9 m
Max. outreach	9,5 m
Platform height	16,9 m
Max. load in basket	230 kg
Basket dimensions	1,4 x 0,7 x 1,1 m
Turret rotation	+/- 178° (356° non-continuous)
Total weight	2435 Kg

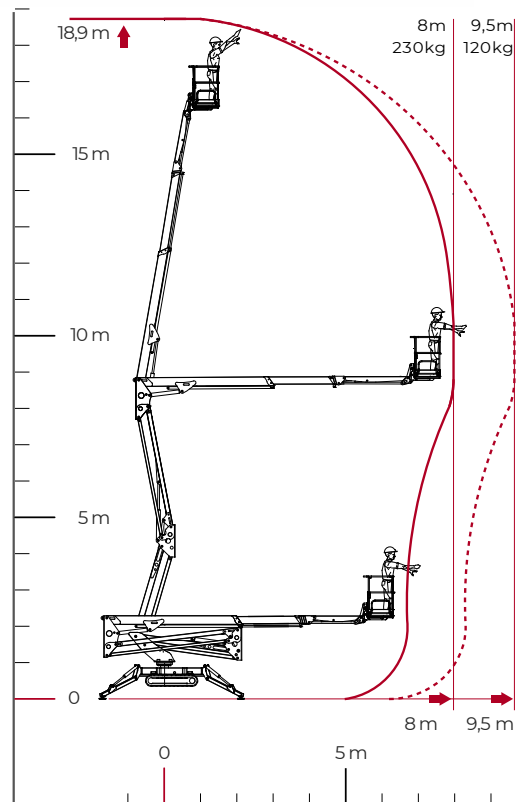

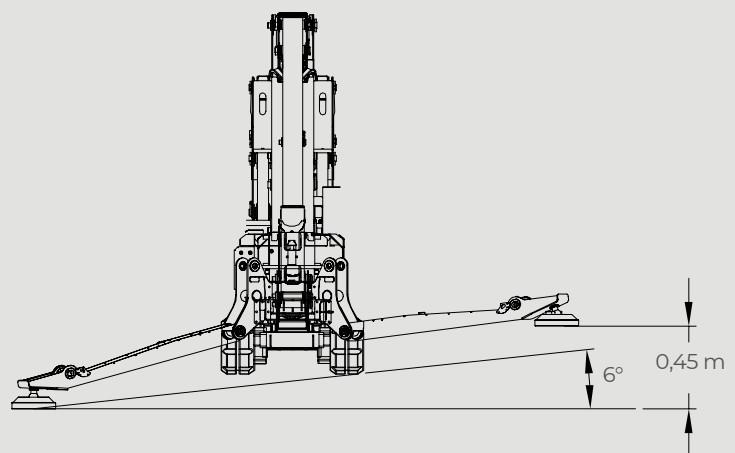
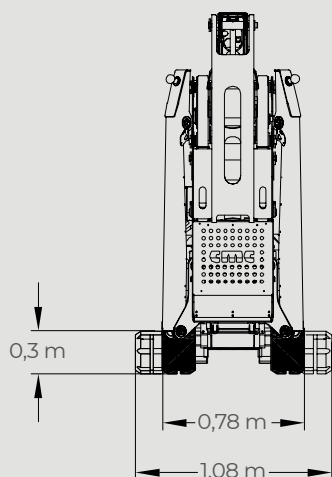
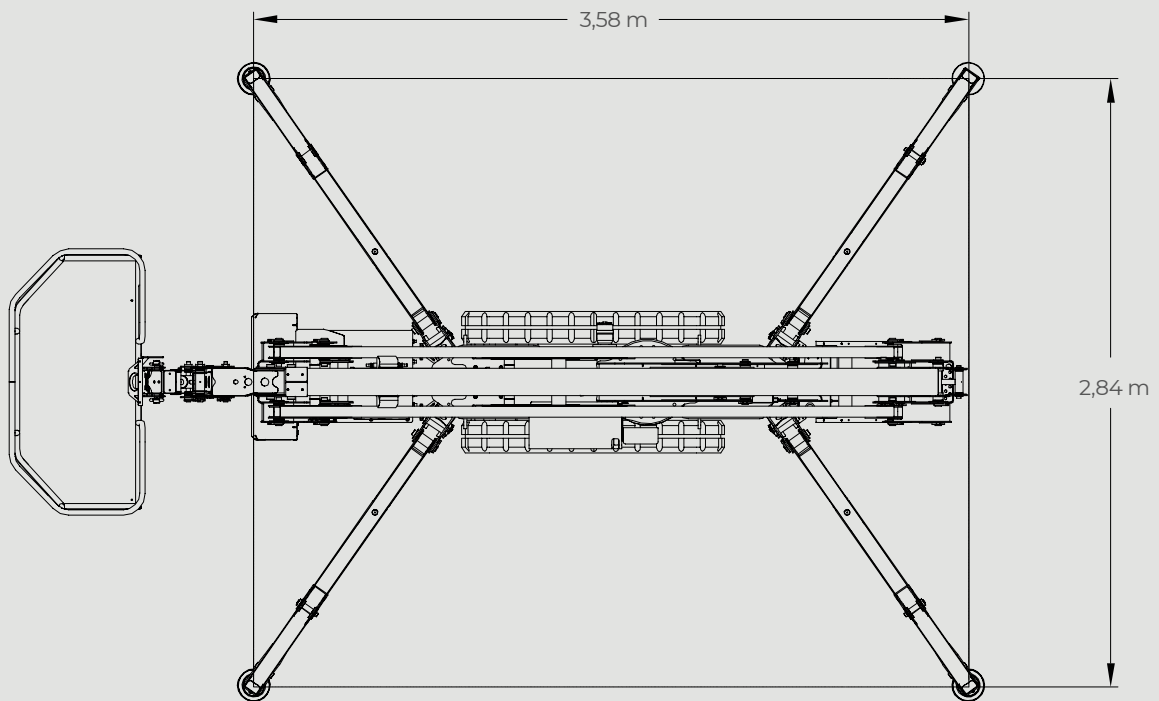
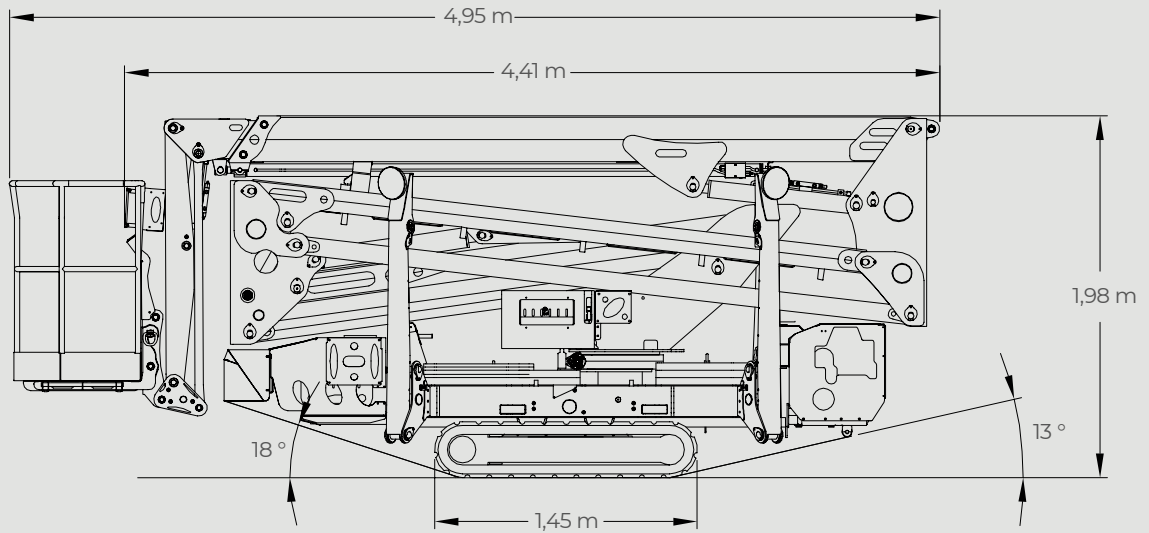

*data may can change due to updates of components

TECHNICAL DATA

S23

PERFORMANCE AND DIMENSIONS



Main features

With the excellent combination of weight, strength and working height, it's the most compact platform with the longest outreach in its category. Equipped with the Self Control System, developed by CMC, for automatic stabilisation control, manoeuvring speed, automatic closure of the aerial part and collision prevention.

Max. working height	23 m
Max. outreach	12,4 m
Platform height	21 m
Max. load in basket	200 kg
Basket dimensions	1,4 x 0,7 x 1,1 m
Basket rotation	+/-90° (option)
Turret rotation	+/- 355° (710° continuous)
Total weight	2880 Kg

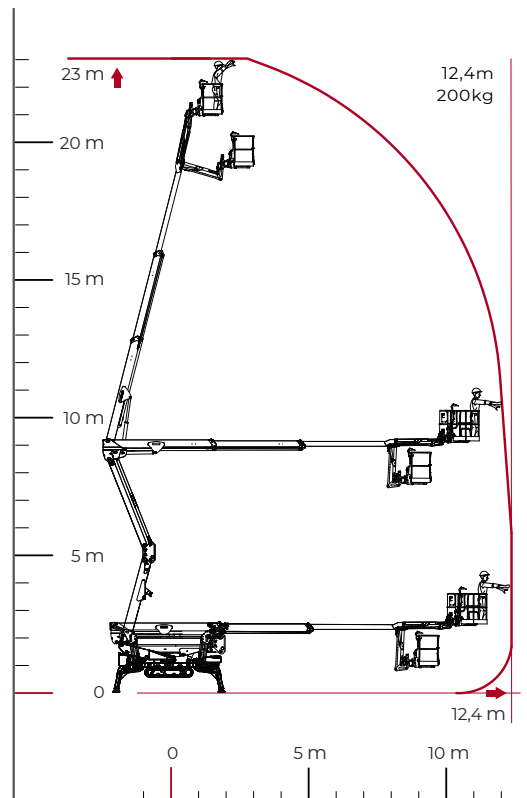

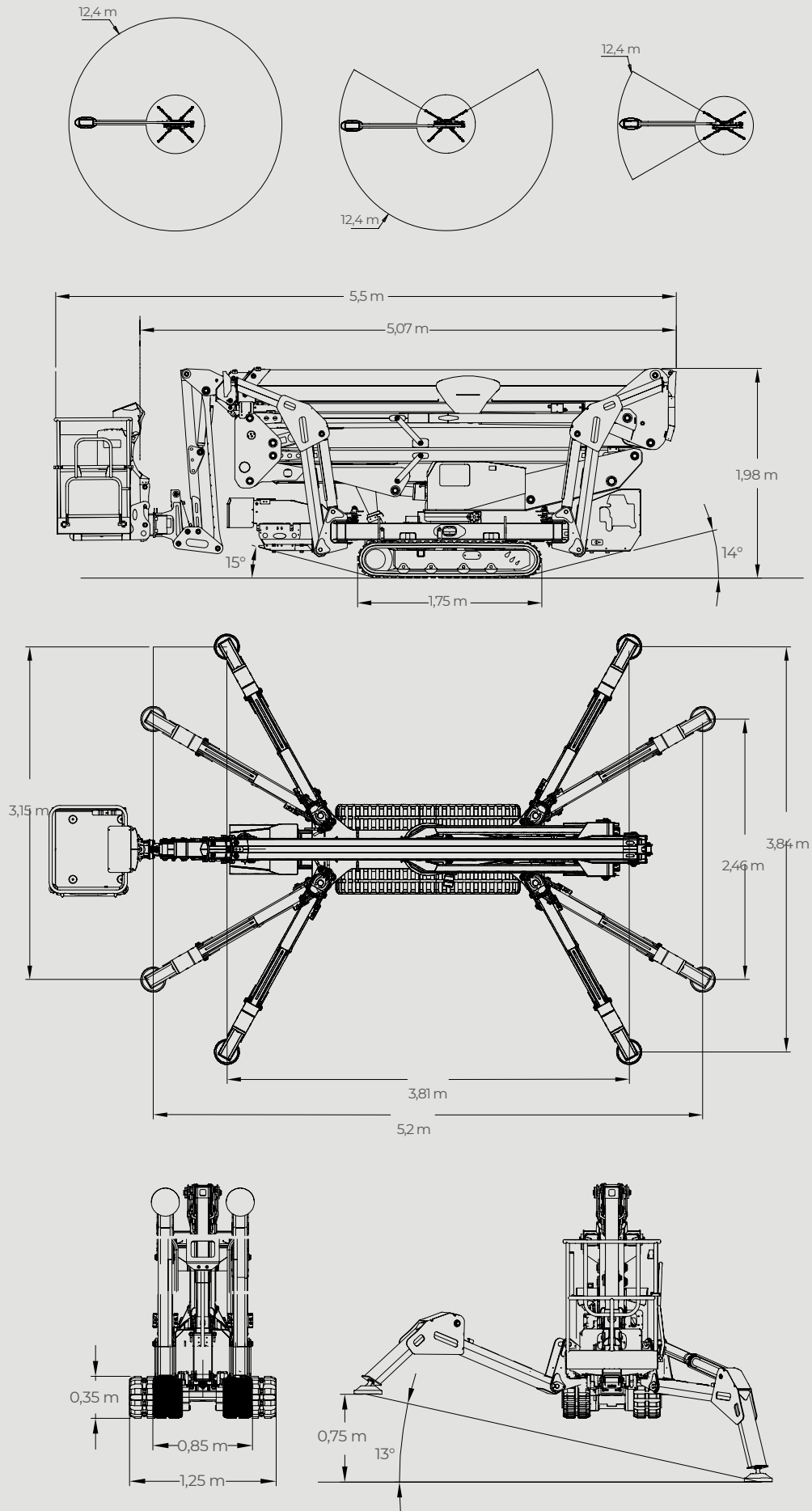

*data may can change due to updates of components

CMC SELF-PROPELLED CRAWLER PLATFORMS

F SERIES

MODEL	MAX. WORKING HEIGHT	MAX. OUTREACH	WEIGHT
S13F	12,9 m	8,5 m	1565 Kg
S15F	14,8 m	8,7 m	2378 Kg
S18F	17,78 m	11,15 m	2495 Kg

LC SERIES

MODEL	MAX. WORKING HEIGHT	MAX. OUTREACH	WEIGHT
S15	14,9 m	6,9 m	1820 Kg
S19E	18,7 m	9,3 m	2545 Kg
S19N	18,9 m	9,5 m	2435 Kg
S23	23 m	12,4 m	2880 Kg

HD SERIES

MODEL	MAX. WORKING HEIGHT	MAX. OUTREACH	WEIGHT
S19HD	18,7 m	11,4 m	2685 Kg
S22HD	21,6 m	12,5 m	3025 Kg

DP SERIES

MODEL	MAX. WORKING HEIGHT	MAX. OUTREACH	WEIGHT
S27	27,3 m	15,4 m	4109 Kg
S30	30,3 m	15,4 m	4285 Kg
S32	32 m	16 m	7255 Kg

XL SERIES

MODEL	MAX. WORKING HEIGHT	MAX. OUTREACH	WEIGHT
S41	41 m	19 m	13460 Kg

i SERIES

MODEL	MAX. WORKING HEIGHT	MAX. OUTREACH	WEIGHT
i23	23 m	10 m	3930 Kg

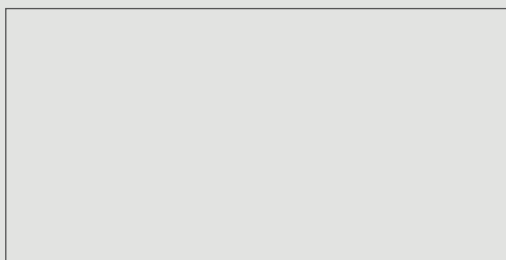

CMC
THE SPECIALIFT

Via Bitritto, 119 - 70124 BARI - ITALY
Tel. +39 080 532 66 06 - Fax +39 080 536 85 41
www.cmclift.com - info@cmclift.com

Follow us on

