



## SAFETY NOTICE MANDATORY ACTION REQUIRED

**SUBJECT:**
**- SAFETY HARNESS ATTACHMENT POINTS USED AS AN ANCHORAGE POINT FOR TRANSPORT**

**ISSUE:** CMC has been informed of the incorrect use (misuse), namely not in accordance with the user manual, of the safety harness attachments used to secure the machine to trailers and trucks for transport. **The force applied caused the basket bracket to brake AND CAN LEAD TO SERIOUS INJURY OR FATALITY.**

**CMC IS REQUIRING ALL OWNERS/OPERATORS OF LIFT MODELS S32/105HD+ TO IMMEDIATELY INSPECT THE BASKET BRACKET AND THE ENTIRE STRUCTURE OF THE LIFT LOOKING FOR DAMAGES.**

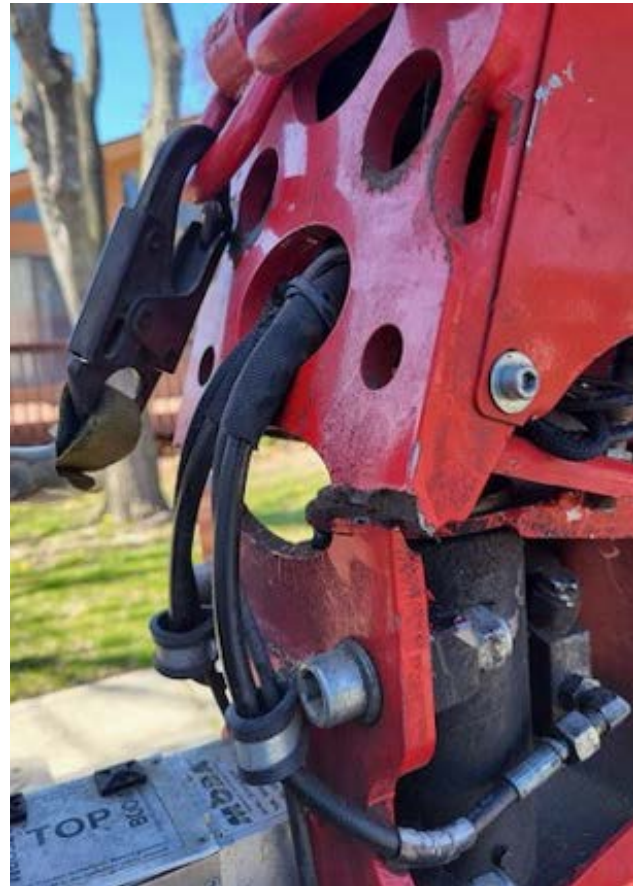
*Picture 1*

*Picture 2*
**ISSUE**

**CMC has been notified of cases of safety harness attachments points used to secure the machine to trailers and trucks for transport purposes.(picture 1 and picture 2)**

- The improper use of the safety belts anchorage points to secure the machine during transport has caused the breakage of the basket bracket (picture 1 and picture 2) and can lead to serious injury or death.

**NOTICE: THIS SAFETY BULLETIN SUPERSEDES ALL PREVIOUS CMC SAFETY BULLETIN AND/OR EMAILS RELEASED BY CMC FOR THE ISSUE AT HAND.**

**DATE OF ISSUE MAY 2ND, 2023**

**SAFETY NOTICE  
MANDATORY ACTION REQUIRED****WARNING**

- IMMEDIATELY STOP USE THE SAFETY HARNESS ANCHORAGE (*picture 1 and 2*) TO SECURE THE MACHINE FOR TRANSPORT PURPOSES.
- OWNERS AND USERS MUST IMMEDIATELY INSPECT THE SAFETY HARNESS ANCHORAGE POINT AND THE ENTIRE STRUCTURE OF THE LIFT.
- THE IMPROPER USE OF THE SAFETY BELTS ANCHORAGE POINTS TO SECURE THE MACHINE DURING TRANSPORT HAS CAUSED THE BASKET BRACKET TO BREAK AND CAN LEAD TO SERIOUS INJURY OR DEATH.
- ALWAYS READ AND FOLLOW ALL INSTRUCTIONS IN THE SERVICE AND MAINTENANCE MANUAL AND THE OWNER'S MANUAL.

*Picture 3*

**SAFETY NOTICE  
MANDATORY ACTION REQUIRED**

**ACTION:** The owner must inspect their equipment and check for any possible damage to the basket bracket and on the entire lift structure as per Picture 1, 2, 3 and 4.



Picture 4

**WARNING**

If the inspection reveals any damage to the basket bracket as specified in picture 1, 2 and 3 or any other spot on the lift structure, the owner **MUST** stop any use of the lift immediately and contact a Dealer or CMC directly.

As a reminder, the machine's Owner's Manual requires daily inspection of the machine and to perform periodically the maintenance, according with the working hours and the general conditions of the machine.



## SAFETY NOTICE MANDATORY ACTION REQUIRED

Additional reminder to owners and users: the user manual includes all fixing point for transport and these are the only point to be used during this operation.

Correct fixing points for transport are showed in Sample 1.

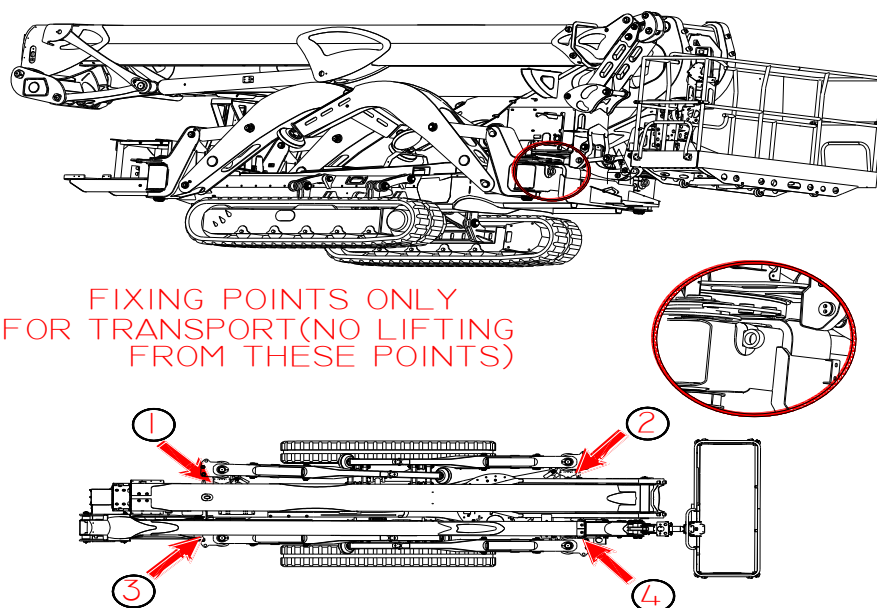

*Sample 1*

If you require additional copies of this bulletin or have any question, please contact CMC Utilities at **+390805326606** or at **servicecmc@cmclift.com**